



ODC 915TM OUTDOOR DISCOVERY CRAFTTM

ASSEMBLY INSTRUCTIONS

Your ODC 915 Pontoon Boat comes in two separate cartons consisting of the following parts:

ALUMINUM FRAME

- (1) Left Frame Member
- (1) Right Frame Member
- (1) Seat Support Frame Member with Underseat Lift and Lock Anchor System Attached
 - (2) Foot Bars
 - (8) Short Snap Pins
 - (2) Side Storage Pockets
- (1) Cargo Deck (with protective bar for shipping attached)
 - (1) Anchor Line Storage Bag
 - (1) Rod Holder
 - (1) Plastic Padded Seat Back
 - (1) Plastic Padded Seat Bottom
 - (4) Seat Screws
 - (2) Seat Assembly Pins

OARS & OARLOCKS

- (1) Pair 7 foot, 3 piece oars
- (1) Pair bronze oarlocks, with split rings
 - (1) Pair Oar Stops
 - (2) Oarlock Bushings

WARRANTY CARD & PATCH KIT

STRIPPING APRON

PONTOONS

- (1) Pair pontoons: Each pontoon consists of 30 oz. PVC thermal welded cover, 420 denier nylon liner and 30 gauge PVC bladder with valve insert and valve plate all pre-assembled.
- (8) Cam-lock straps

(1) PUMP

Complete with a set of adapters

ODC 915™

OUTDOOR DISCOVERY CRAFT

ASSEMBLY INSTRUCTIONS

I. PADDED SEAT ASSEMBLY

1. Assemble Seat Back to Seat Bottom using Seat Pins (see figure 1).

II. FRAME ASSEMBLY

NOTE: Your frame assembles using (8) Short Snap Pins and (4) Screws for seat installation. Please follow instructions accordingly. See figure 3 for Snap Pin installation.

1. Assemble Seat to Seat Support Frame Member using 4 seat screws (see figure 1).
2. Assemble Seat Support Member to Left and Right Frame Members using (4) Short Snap Pins (see figure 4).
3. Remove Protective Support Bar and assemble Cargo Deck to back of Left and Right Frame Member using (2) Short Snap Pins (see figure 4)
4. Assemble Foot Bars to front of Left and Right Frame Member (see figure 4).
5. See figure 9 and 11 for use of Underseat Lift and Lock Anchor System.

III. PONTOON INFLATION

NOTE: Use the large cone adapter provided with your pump. See figure 7 for a detail of the valve assembly. Before inflation, be sure to fully seat each valve assembly into the pontoon, screwing tightly by hand. When fully seating valve assembly, be sure that the valve plate is in place around valve assembly and not restricting the valve assembly from a full seal. After inflating, be sure to fully seat the top cap on to each valve assembly, screwing tightly by hand. Both are required for an airtight seal.

1. Inflate each pontoon. The valve is located at the top and center of each Pontoon (see figure 5). Inflate until firm (do not over inflate).
2. **Again, be sure top valve cap and valve assembly are fully seated to achieve airtight seal.**

PONTOON DEFLATION: Unscrew entire valve assembly from pontoon.

IV. ATTACH PONTOONS TO FRAME

NOTE: Always inflate the Pontoons first, before attaching to frame.

1. Position inflated Pontoons under the Left and Right Frame Members with ODC 915 logo oriented to the outside.
2. Attach each Pontoon to frame using (8) Cam Lock Straps. Slip each strap through D-Ring on Pontoon, around frame and pull tight through Cam Lock Buckle. **NOTE:** Be sure the straps are pulled tight through the Cam Lock Buckles (see figure 6).

V. OAR & OARLOCK ASSEMBLY

1. Slide the Oar Stop over the handle end of the Oar Shaft and tighten Oar Stops with nut and bolt provided.
2. Assemble 2 oar shaft pieces and blades.
3. Place Oarlock Bushing over Oarlock shaft and place Oarlock into frame. Frame has 3 Oarlock postions for a custom fit. Attach split ring at end of Oarlock shaft to secure Oarlock in place (see figure 8)

VI. ATTACH SIDE STORAGE POCKETS TO FRAME

1. Position Side Storage Pockets along Left Frame Member and Right Frame Member.
(see figure 5)
2. Wrap hook & loop straps around upper rail frame and strap down.
3. Wrap lower hook & loop straps around bottom rail of frame and strap down.

VII. ATTACH STRIPPING APRON

1. Snap front two straps around the frame underneath the oarlocks, and snap the back two straps to the Right and Left Frame Members just behind the Side Storage Pockets.

VIII. ATTACH ROD HOLDER TO FRAME

1. Rod Holder attaches to frame using Snap Pin where Cargo Deck and Frame Members meet (can be attached to left or right side).

X. ATTACH ANCHOR LINE STORAGE BAG

1. Anchor Line Storage bag attaches to front of Seat Support Frame Member (see figure 10).

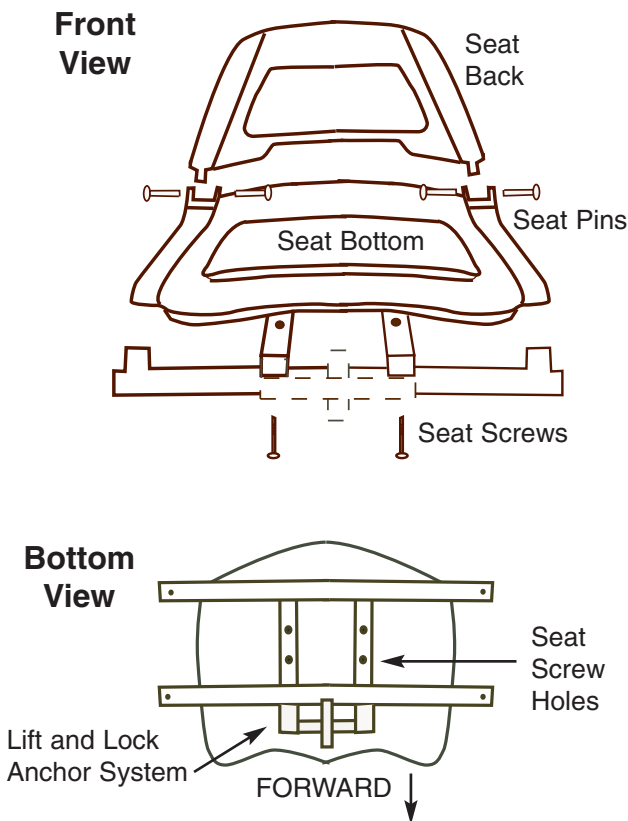

Figure 1
Seat Assembly

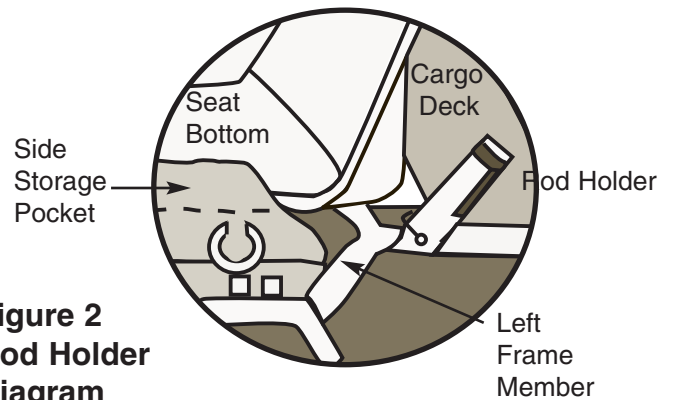

Figure 2
Rod Holder
Diagram

Shown attached to the left side of boat.

Fig. 3 Detail of Snap Pin Installation

All frame parts attach with snap pins.
Your frame assemblies using (8) short snap pins. Please follow instructions accordingly.

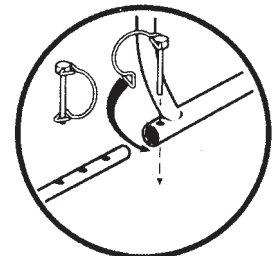
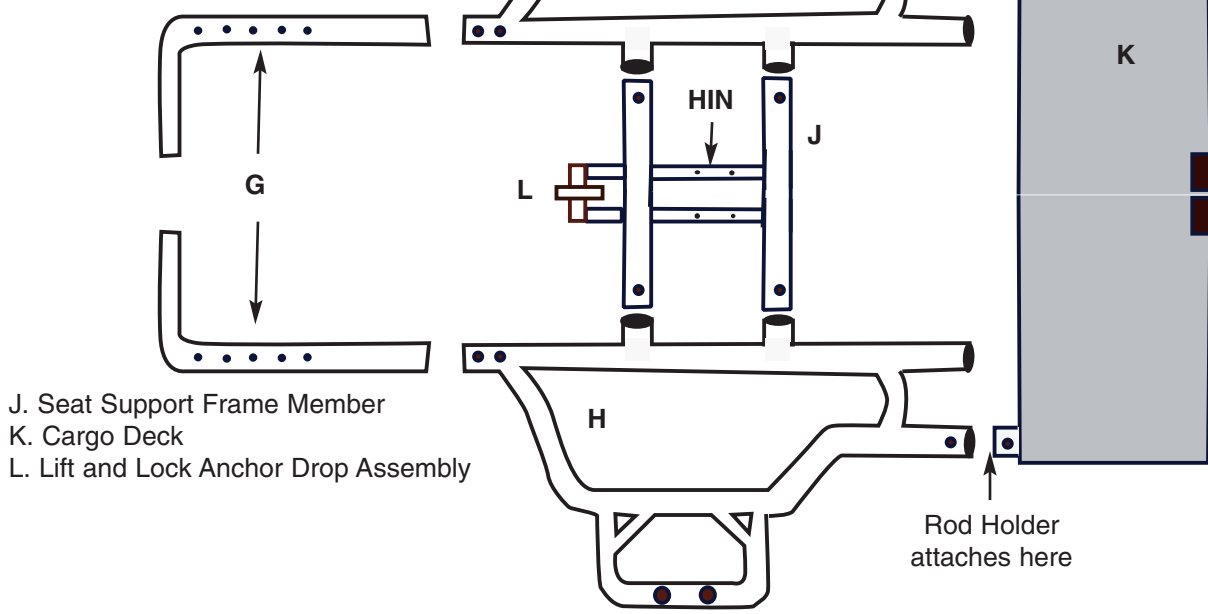

Figure 4
Frame Assembly

- G. Foot Bars
- H. Left Frame Member
- I. Right Frame Member



- J. Seat Support Frame Member
- K. Cargo Deck
- L. Lift and Lock Anchor Drop Assembly

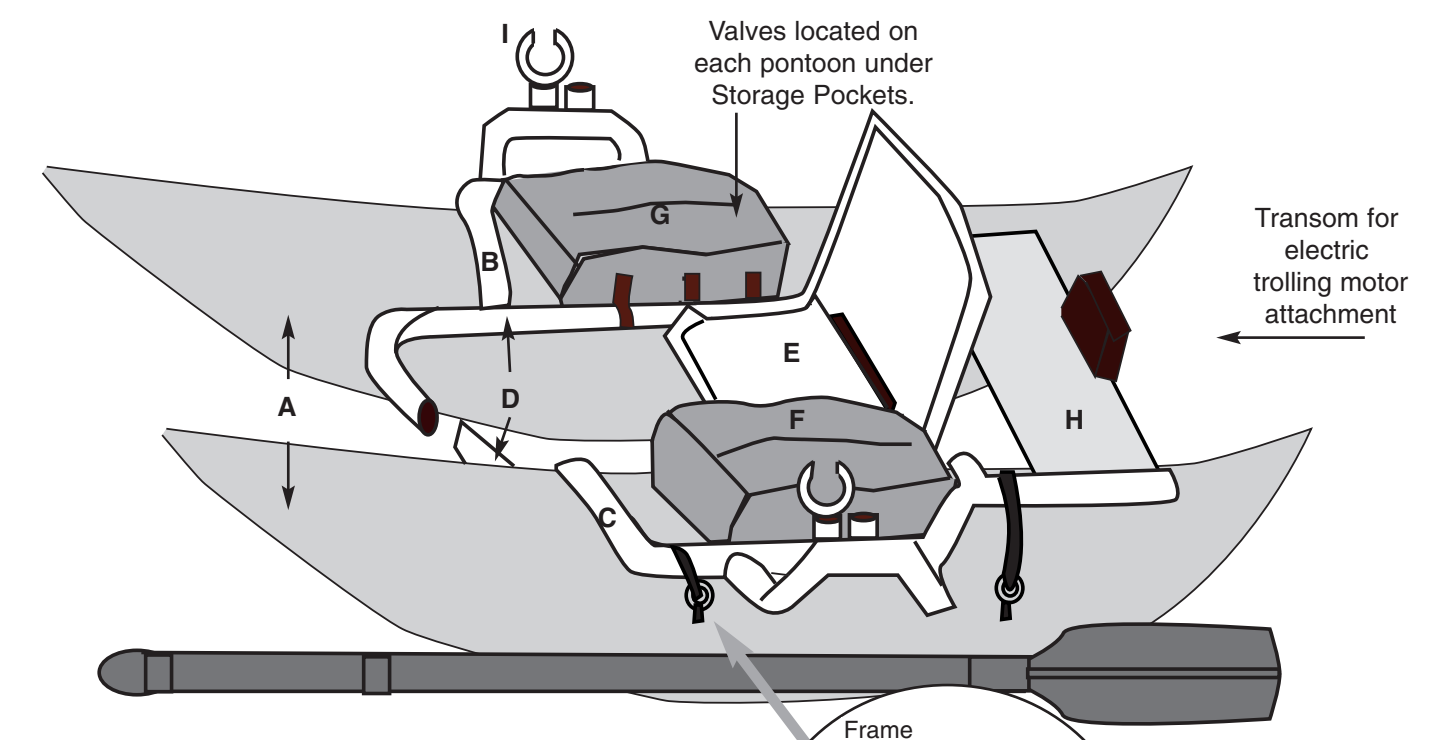

Figure 5
Assembled ODC 1018

- A. Pontoons
- B. Right Frame Member
- C. Left Frame Member
- D. Foot Bars
- E. Padded Plastic Seat
- F & G Side Storage Pockets
- H. Cargo Deck
- I. Oar Lock

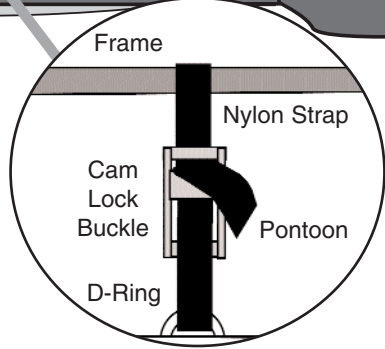

Figure 6
Detail of Nylon Strap & Cam Lock Buckle

Figure 7 Valve Insert detail

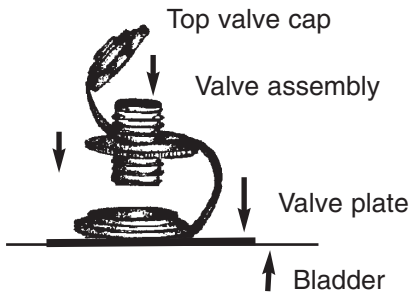

Figure 8 Oar Lock Detail

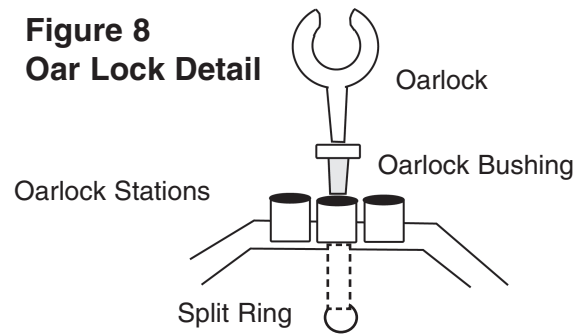
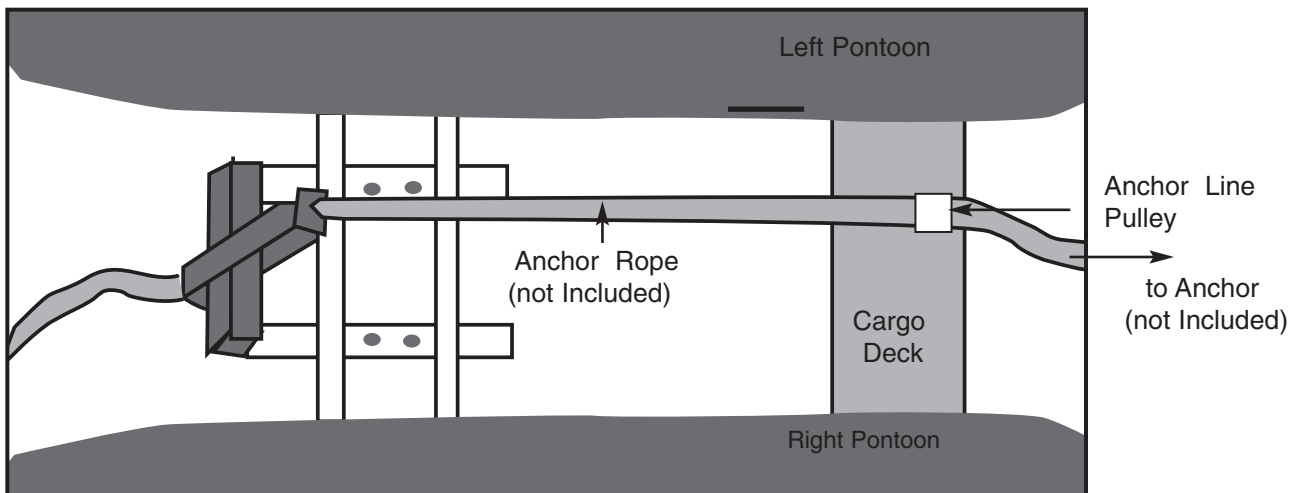

Figure 9 Underneath View of Underseat Lift and Lock Anchor System

Designed to be used while sitting in seat.

← To Front of Boat



Underneath View of Boat

To Back of Boat →

Figure 10 Anchor Line Storage Bag Attachment

Bag straps to front of Seat Support Frame Member for easy storage of excess anchor line.

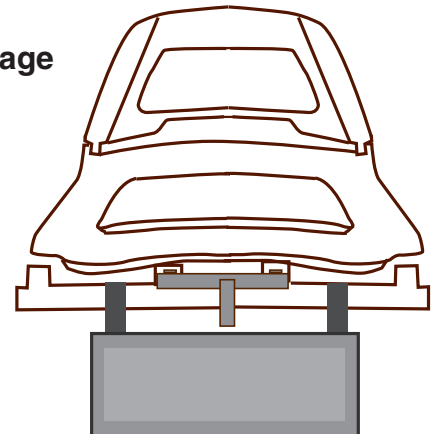
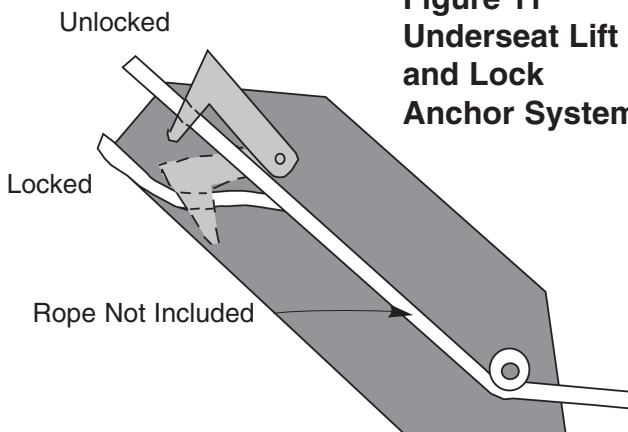

Figure 11 Underseat Lift and Lock Anchor System



ODC 915™

OUTDOOR DISCOVERY CRAFT™

Your ODC Outdoor Discovery Craft is designed to give you many years of service.

Please follow inflation instructions and warnings carefully.

IF YOU EVER HAVE ANY QUESTIONS OR PROBLEMS WITH YOUR ODC 915 PLEASE DO NOT RETURN IT TO THE DEALER YOU BOUGHT IT FROM. PLEASE CONTACT THE CREEK COMPANY DIRECTLY TOLL FREE AT 1-800-843-8454. WE ARE OPEN M-F 9AM-5PM MOUNTAIN TIME. OR CONTACT US VIA E-MAIL AT INFO@CREEKCOMPANY.COM.

HIN IS LOCATED ON SQUARE TUBING OF SEAT SUPPORT FRAME MEMBER AND ON RIGHT MAIN FRAME MEMBER (SEE FIGURE 4)

Warning:

Please read and follow carefully.

1. Always wear a US Coast Guard approved personal floatation device when in your ODC 915.
2. Never float alone.
3. Always check your ODC 915 air bladders, frame, oar components, and covers for possible damage before you use your craft.
4. Never use your craft if you suspect the air bladders, frame, oar components, or cover has been damaged.
5. Never over inflate your ODC 915.
6. Never use your ODC 915 without the pontoons fully inflated.

CARE AND MAINTENANCE:

1. If your pontoon bladder is losing air, please check that valve assembly and top valve cap are fully seated. Reseat valve assembly and repeat pontoon inflation instructions.
2. Do not store your ODC 915 in direct sunlight.
3. If you are leaving your ODC 915 out in the sun for any amount of time, be aware that the heat can increase the pressure inside the pontoons to a dangerous level. Let some of the air out of the pontoons if the craft will be out of the water in the sun for any length of time, or if it is stored in a vehicle, etc.
4. A gain in altitude will increase the pressure in the pontoons also. If you are taking your inflated ODC 915 from a low elevation to a high elevation, be sure to let some of the air out of it.
5. For short term storage, we recommend you let some air out of your pontoons.
6. For long term storage, we recommend you make sure your ODC 915 is completely dry, deflated and stored out of the sunlight in a cool dry area.
7. Repairing bladder, use enclosed patch kit. Fully deflate bladder. Remove safety split-ring from zipper pull and open zipper in pontoon cover. Remove bladder from inner liner. Identify puncture. Clean and dry area around puncture. Apply glue to puncture area and patch using applicator straw. Press patch over area. Allow 24 hours to dry before inflation.
8. Note: Metal parts may rust and are not covered under warranty.



Accessories are available for your ODC 915. Ask for them where you bought your ODC 915, or visit the Creek Company Store at www.creekcompany.com

The Creek Company Ltd. , PO Box 773892, Steamboat Springs, CO 80477

email: info@creekcompany.com

Specifications and other details subject to change without notice.

All Creek Company products are guaranteed against defects in material and workmanship for the life of the product to the original owner. This does not cover damage due to misuse or normal wear and tear.