



ODC CLASSIC XL™ OUTDOOR DISCOVERY CRAFT™

ASSEMBLY INSTRUCTIONS

THIS BOX CONTAINS:

STEEL FRAME

- | | |
|-------------------------------|------------------------|
| (1) Left Frame Member | (1) Right Frame Member |
| (1) Seat Support Frame Member | (1) Plastic Seat Back |
| (1) Plastic Seat Bottom | (2) Seat Assembly Pins |
| (4) Seat Screws | (2) Foot Bars |
| (1) Rear Frame Member | (1) Mesh Cargo Deck |
| (1) Stripping Apron | (8) Snap Pins |

OARS & OARLOCKS

- (1) Pair 6-foot 2 piece Oars
- (1) Pair Clamp-on Oarlocks
- (2) Oarlock Bushings

PONTOONS

- (1) Left Pontoon
- (1) Right Pontoon
- (8) Cam Lock Straps

Each Pontoon consists of Nylon Cover with PVC bottom featuring integral Side Storage Pockets and bladder with Pro Series Valves.

Valve Adapter and Valve Wrench

PATCH KIT

WARRANTY CARD

ODC CLASSIC XL™

OUTDOOR DISCOVERY CRAFT™

ASSEMBLY INSTRUCTIONS

I. PLASTIC SEAT ASSEMBLY

1. Assemble Seat Back to Seat Bottom using Seat Assembly Pins (see figure 1a).

II. ASSEMBLE FRAME

NOTE: Your Frame Assembles using (8) Snap Pins. Please follow instructions accordingly.

1. Assemble Cargo Deck by sliding Mesh Cargo Deck over Rear Frame Member (see figure 1) and secure using attached Hook and Loop and Ladder Lock / Strap Fasteners.
2. Assemble Seat to Seat Support Frame Member using (4) Seat Screws. (See Figure 1a)
3. Assemble Seat Support Frame Member to Left and Right Frame Members using (4) of the Snap Pins. (see figure 1)
4. Assemble Cargo Deck to Left and Right Frame Members using (2) Snap Pins (see figure 1).
5. Assemble Foot Bars to Left and Right Frame Members using (2) Snap Pins (see figures 1).

III. PONTOON INFLATION

NOTE: Use double action pump (not included), available from Creek Company. Or use any standard double action pump using Valve Adapter included with your Classic XL.

1. Inflate each Pontoon. The Valve is located inside the Storage Pocket of each Pontoon.(see figure 3). Inflate until firm (do not over inflate).

PONTOON DEFLATION: Depress center valve button and turn clockwise 1/4 turn to lock open. Depress and turn 1/4 turn counter clockwise to close the valve.

IV. ATTACH PONTOONS TO FRAME

NOTE: Always inflate the Pontoons first, before attaching to Frame.

1. Position inflated Pontoons under the Left and Right Frame Members with ODC CLASSIC XL™ logos oriented to the outside. The Frame Members fit around the Storage Pockets.
2. Attach Pontoons to Frame as illustrated in figures 3 and 3a. Note: Be sure the Straps are pulled tight through the Cam-lock Buckles. Frame should be positioned forward or aft on the Pontoons to achieve center of gravity for an even ride when fully loaded on the water.

V. OAR & OARLOCK ASSEMBLY

1. Loosen the wingnut on the Oarlock and slide the Oarlock onto the handle end of the Oar Shaft.
2. Attach blade end of Oar to end of Oar Handle.
3. Place Oarlock Shafts into Frame.
4. With the Oarlocks installed on the Frame, the oars should be equally adjusted left and right allowing at least two thumbs' distance between the Oars, to avoid pinching your thumbs when rowing. With the blades perpendicular to the water, tighten the wingnuts.

VI. ATTACH STRIPPING APRON TO FRAME

1. Snap front two Straps around the Frame underneath the Oarlocks, and snap the back two Straps to the Right and Left Frame Members just behind Storage Pockets.

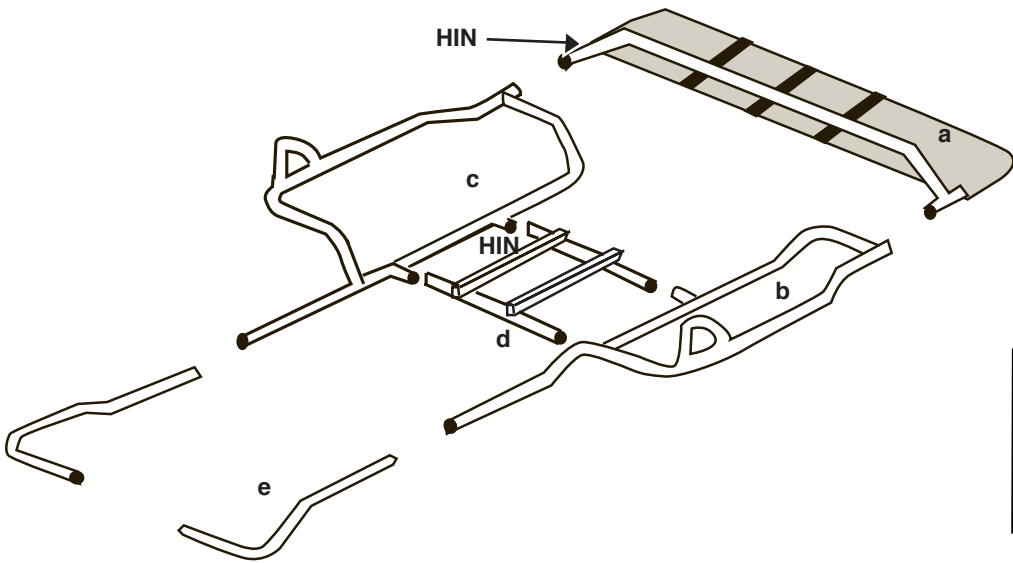

Fig. 1
Frame assembly

- a. Cargo Deck (Rear Frame Member with Mesh Cargo Deck) (assembly required)
- b. Left Frame Member
- c. Right Frame Member
- d. Seat Support Frame Member
- e. Foot Bars

Accessories are available for your ODC Classic XL™
Visit www.CreekCompany.com for details or call 970-879-5221x 300

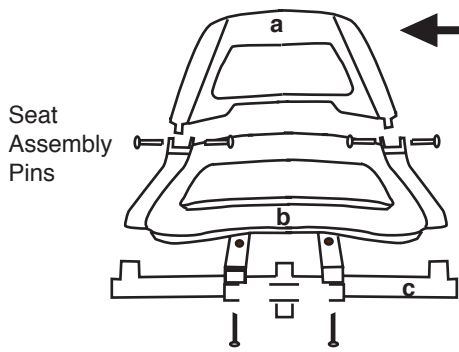

Fig. 1a
Seat Frame assembly

- a. Plastic Seat Back
- b. Plastic Seat Bottom
- c. Seat Support Member

Fig. 3
Pontoon-to-Frame attachment
Frame slips over two Storage Pockets

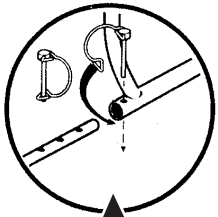
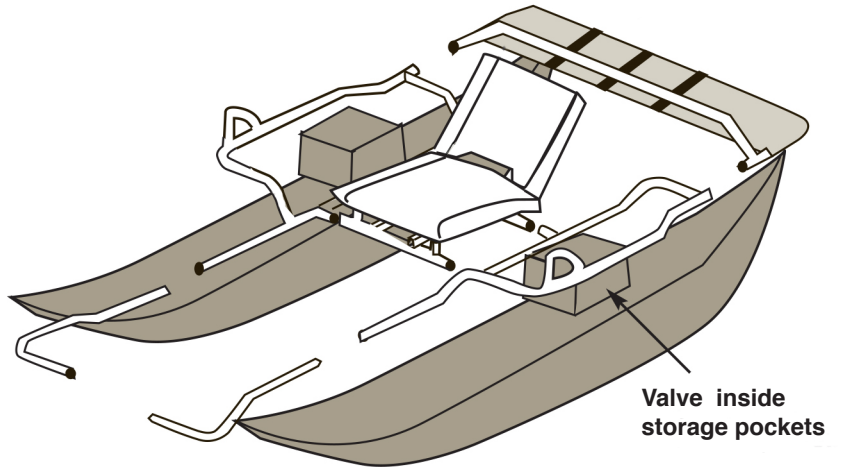
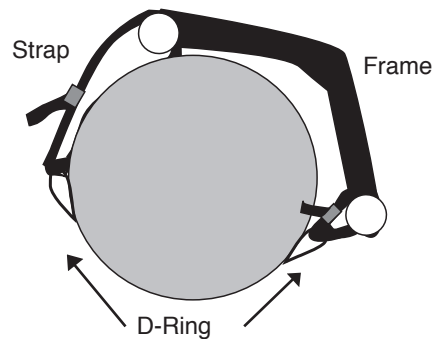

Fig. 2
Detail of Snap Pin installation

All Frame parts attach with Snap Pins.
Your Frame assembles using (8) Snap Pins. Please follow instructions accordingly.

Fig. 3a
Pontoon-to-frame attachment
Detail of Camlock Strap



ODC CLASSIC XL™ OUTDOOR DISCOVERY CRAFT™

Your ODC Outdoor Discovery Craft™ is designed to give you many years of service.

Please follow inflation instructions and warnings carefully.

IF YOU EVER HAVE ANY QUESTIONS OR PROBLEMS WITH YOUR ODC CLASSIC XL™ PLEASE DO NOT RETURN IT TO THE DEALER YOU BOUGHT IT FROM. PLEASE CONTACT THE CREEK COMPANY DIRECTLY AT 970-879-5221. WE ARE OPEN M-F 9AM-5PM MOUNTAIN TIME. OR CONTACT US VIA E-MAIL AT INFO@CREEKCOMPANY.COM.

HIN is located on square tubing of seat support frame member and on right main frame member (See Figure 1)

Your Creek Company Classic XL™ is guaranteed against defects in material and workmanship for the life of the product to the original owner. This does not cover damage due to misuse or normal wear and tear.

Warning:

Please read and follow carefully.

1. Always wear a US Coast Guard approved personal flotation device when in your ODC CLASSIC XL™.
2. Never float alone.
3. Always check your ODC CLASSIC XL™ Air Bladders, outer skin and stitching for possible damage before you use your craft.
4. Never use your craft if you suspect the Air Bladders, outer skin or stitching has been damaged.
5. Never overinflate your ODC CLASSIC XL™.
6. Never use your ODC CLASSIC XL™ without the Pontoons fully inflated.
7. Your ODC CLASSIC XL™ is not designed for use in salt water.

CARE AND MAINTENANCE:

1. Do not store your ODC CLASSIC XL™ in direct sunlight.
2. If you are leaving your ODC CLASSIC XL™ out in the sun for any amount of time, be aware that the heat can increase the pressure inside the Pontoons to a dangerous level. Let some of the air out of the pontoons if the craft will be out of the water in the sun for any length of time, or if it is stored in a vehicle, etc.
3. A gain in altitude will increase the pressure in the Pontoons also. If you are taking your inflated ODC CLASSIC XL™ from a low elevation to a high elevation, be sure to let some of the air out of it.
4. For short term storage, we recommend you let some air out of your pontoons.
5. For long term storage, we recommend you make sure your ODC CLASSIC XL™ is completely dry, deflated and stored out of the sunlight in a cool dry area.. Do not store your wet ODC CLASSIC XL™ in freezing temperatures as this may result in Frame and other component damage.
6. Repairing Bladder, use enclosed patch kit. Identify puncture. Fully deflate Bladder. Clean and dry area around puncture. Apply glue to puncture area and patch using applicator straw. Press patch over puncture area. Allow 24 hours to dry, before inflating.
7. Note: Metal parts may rust and are not covered under warranty.

View Instructional Video at www.creekcompany.com



Accessories are available for your ODC CLASSIC XL™.
Ask for them where you bought your ODC CLASSIC XL™ or visit the
Creek Company Store at www.CreekCompany.com

Creek Company, PO Box 773892, Steamboat Springs, CO 80477

email: info@CreekCompany.com

Made in China

Specifications and other details subject to change without notice.