



ODC JETPACK™

OUTDOOR DISCOVERY CRAFT™

ASSEMBLY INSTRUCTIONS

THIS BOX CONTAINS:

ALUMINUM FRAME

- (1) Left Frame Member
- (1) Right Frame Member
- (1) Seat Support Frame Member
- (1) Padded Seat Assembly
- (1) Left Foot Bar Extension
- (1) Right Foot Bar Extension
- (2) Foot Bars
- (1) Rear Frame Member
- (1) Mesh Cargo Deck
- (1) Stripping Apron
- (12) Short Snap Pins

OARS & OARLOCKS

- (1) Pair 6-foot 2 piece Oars
- (1) Pair Clamp-on Oarlocks

PONTOONS

- (1) Left Pontoon
- (1) Right Pontoon

Each Pontoon consists of 840 Denier Nylon Cover with integral Side Storage Pockets, Straps and Cam-lock Buckles to secure the Frame; Nylon Liner and Main Bladder with Valve Insert and Valve Plate all preassembled.

PUMP

Complete with a set of Adapters.

BACKPACK

Designed specifically to carry the JETPACK™ when disassembled.

PATCH KIT

WARRANTY CARD

ODC JETPACK™

OUTDOOR DISCOVERY CRAFT™

ASSEMBLY INSTRUCTIONS

I. PONTOON INFLATION

NOTE: Use the Large Cone Adapter provided with your Pump. See figure 3b for a detail of the Valve Assembly. Before inflation, be sure to fully seat each Valve Assembly into the Pontoon, screwing tightly by hand. When fully seating Valve Assembly, be sure that the Valve Plate is in place around Valve Assembly and not restricting the Valve Assembly from a full seal. After inflating, be sure to fully seat the Top Cap on to each Valve Assembly, screwing tightly by hand. Both are required for an airtight seal.

1. Inflate each Pontoon. The Valve is located inside the Storage Pocket of each Pontoon (see figure 3). Inflate until firm (do not over inflate).
2. Again, be sure top Valve Cap and Valve Assembly are fully seated to achieve airtight seal.

PONTOON DEFLATION: Unscrew entire Valve Assembly from Pontoon.

II. ASSEMBLE FRAME

NOTE: Your Frame assembles using (12) Short Snap Pins. Please follow instructions accordingly.

1. Assemble Cargo Deck by sliding mesh Cargo Deck over Rear Frame Member (see figure 1) and secure using attached Hook and Loop and Strap to Ladder Lock Fasteners.
2. Assemble Padded Seat (see figure 1a) by strapping Padded Seat Bottom over the Seat Support Frame Member. Seat back adjusts using Side Straps (see figure 1a)
3. Assemble Seat Support Frame Member to Left and Right Frame Members using (4) of the Short Snap Pins (see figures 1 and 2.)
4. Go to **III. ATTACH PONTOONS TO FRAME** and finish that section before returning to #5
5. Assemble Cargo Deck to Left and Right Frame Members using (2) Short Snap Pins (see figures 1 and 2).
6. Assemble Foot Bar Extensions to Seat Support Frame Member. (see figure 1 and 2)
7. Assemble Foot Bars to Left and Right Frame Members using (2) Short Snap Pins (see figures 1 and 2).

III. ATTACH PONTOONS TO FRAME

NOTE: Always inflate the Pontoons first, before attaching to Frame.

1. Position inflated Pontoons under the Left and Right Frame Members with ODC JETPACK™ logos oriented to the outside. The Frame Members fit around the Storage Pockets.
2. Attach Pontoons to Frame as illustrated in figures 3 and 3a. **NOTE:** Be sure the Straps are pulled tight through the Cam-lock Buckles. Frame should be positioned forward or aft on the Pontoons to achieve center of gravity for an even ride when fully loaded on the water.
3. Go Back to **II. ASSEMBLE FRAME** # 5 and finish Frame assembly.

IV. OAR & OARLOCK ASSEMBLY

1. Loosen the Wingnut on the Oarlock and slide the Oarlock onto the handle end of the Oar Shaft.
2. Attach blade end of Oar to handle end of Oar.
3. Place Oarlock shafts into Frame.
4. With the Oarlocks installed on the Frame, the oars should be equally adjusted left and right allowing at least two thumbs' distance between the Oars, to avoid pinching your thumbs when rowing. With the blades perpendicular to the water, tighten the Wingnuts.

V. ATTACH STRIPPING APRON TO FRAME

1. Snap front two Straps around the Frame underneath the Oarlocks, and snap the back two Straps to the Seat Support Frame behind the Seat Back.

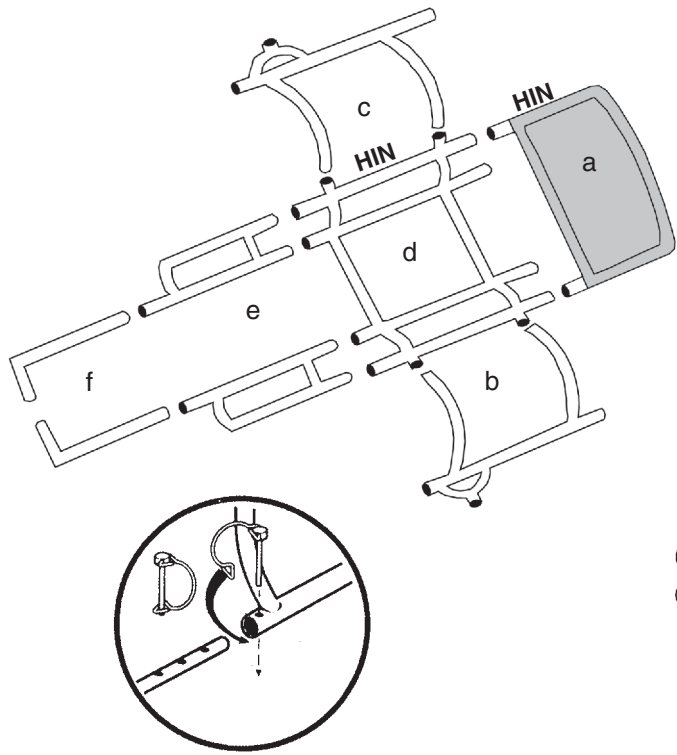

Fig. 1
Frame assembly

- a. Cargo Deck (Rear Frame Member with mesh Cargo Deck; assembly required)
- b. Left Frame Member
- c. Right Frame Member
- d. Seat Support Frame Member
- e. Foot Bar Extensions
- f. Foot Bars

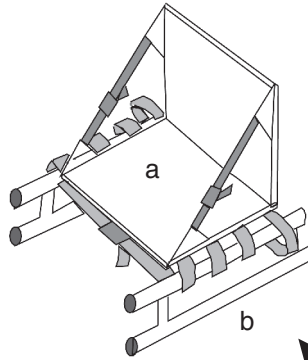

Fig. 1a
Seat Frame assembly

- a. Padded Seat
- b. Seat Support Frame Member

Fig. 2
Detail of Snap Pin installation

All Frame parts attach with S nap Pins.
Your Frame assemblies using (12) Short Snap Pins. Please follow instructions accordingly.

Fig. 3
Pontoon-to-Frame attachment
Frame slips over two Storage Pockets

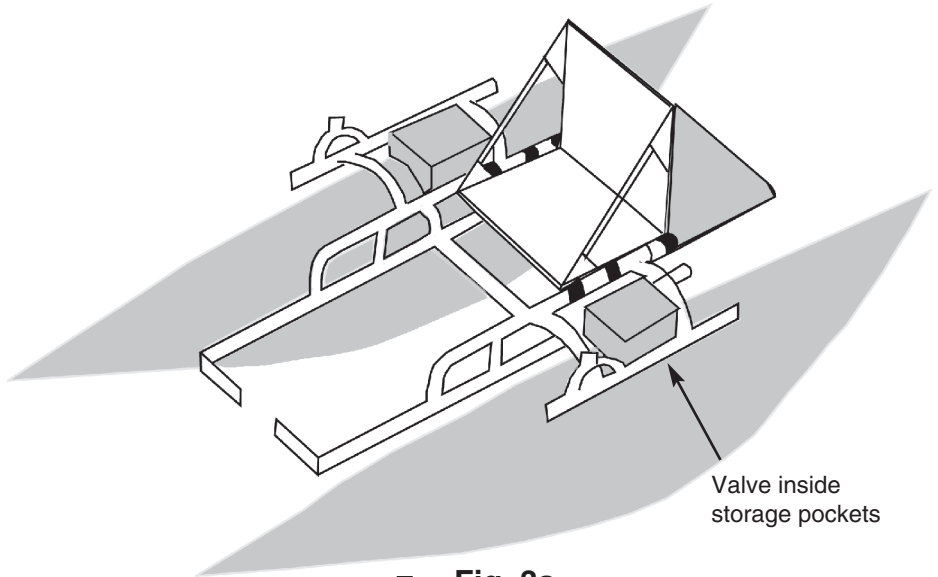
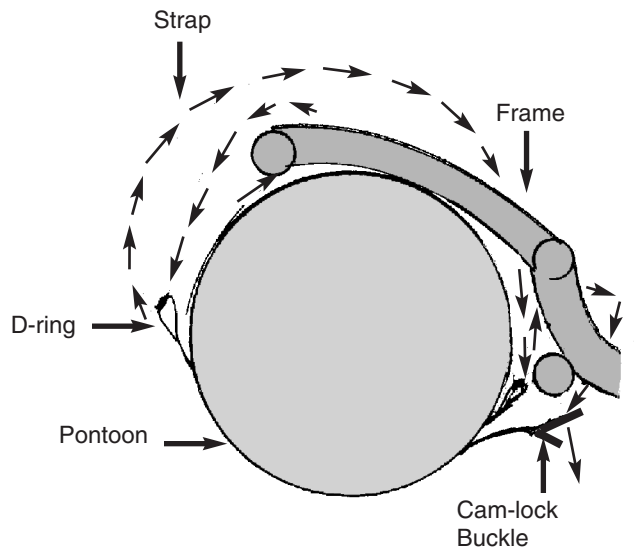

Fig. 3a
Pontoon-to-Frame attachment
Detail of Strap and Cam-lock Buckle.



Backpack

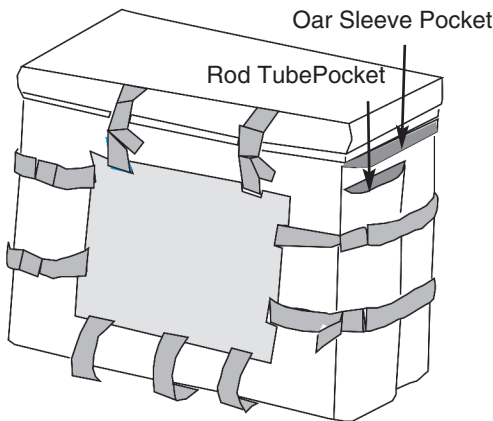
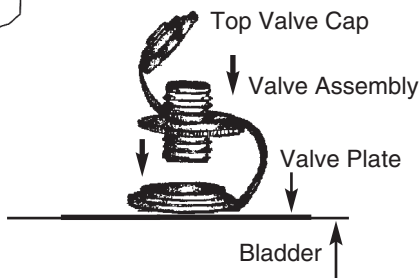

Fig. 3b
Valve insert detail



ODC JETPACK™

OUTDOOR DISCOVERY CRAFT™

Your ODC Outdoor Discovery Craft™ is designed to give you many years of service.

Please follow inflation instructions and warnings carefully.

IF YOU EVER HAVE ANY QUESTIONS OR PROBLEMS WITH YOUR ODC JETPACK™ PLEASE DO NOT RETURN IT TO THE DEALER YOU BOUGHT IT FROM. PLEASE CONTACT THE CREEK COMPANY DIRECTLY TOLL FREE AT 1-800-843-8454. WE ARE OPEN M-F 9AM-5PM MOUNTAIN TIME. OR CONTACT US VIA E-MAIL AT INFO@CREEKCOMPANY.COM

HIN (HULL IDENTIFICATION NUMBER) IS LOCATED ON RIGHT SIDE OF SEAT SUPPORT FRAME MEMBER AND ON RIGHT SIDE OF CARGO DECK FRAME (SEE FIGURE 1)

Warning:

Please read and follow carefully.

1. Always wear a US Coast Guard approved personal flotation device when in your ODC JETPACK™.
2. Never float alone.
3. Always check your ODC JETPACK™ Air Bladders, Frame, Oar components, outer skin and stitching for possible damage before you use your craft.
4. Never use your craft if you suspect the Air Bladders, Frame, Oar components, outer skin or stitching has been damaged.
5. Never over inflate your ODC JETPACK™.
6. Never use your ODC JETPACK™ without the air chambers fully inflated.

CARE AND MAINTENANCE:

1. If your Pontoon Bladder is losing air, please check that Valve Assembly and Top Valve Cap are fully seated. Reseat Valve Assembly and repeat Pontoon inflation instructions.
2. Do not store your ODC JETPACK™ in direct sunlight.
3. If you are leaving your ODC JETPACK™ out in the sun for any amount of time, be aware that the heat can increase the pressure inside the Pontoons to a dangerous level. Let some of the air out of the Pontoons if the craft will be out of the water in the sun for any length of time, or if it is stored in a vehicle, etc.
4. A gain in altitude will increase the pressure in the Pontoons also. If you are taking your inflated ODC JETPACK™ from a low elevation to a high elevation, be sure to let some of the air out of it.
5. For short term storage, we recommend you let some air out of your pontoons.
6. For long term storage, we recommend you make sure your ODC JETPACK™ is completely dry, deflated and stored out of the sunlight in a cool dry area. Do not store your wet ODC JETPACK™ in freezing temperatures as this may result in frame and other component damage.
7. Repairing Bladder, use enclosed Patch Kit. Identify puncture. Fully deflate Bladder. Clean and dry area around puncture. Apply glue to puncture area and patch using applicator straw. Press patch over puncture area. Allow 24 hours to dry, before inflating.
8. Note: Metal parts may rust and are not covered under warranty.
9. We recommend the use of electric trolling motors only on your ODC JETPACK™.
10. Do not use the cargo deck as a standing platform. It is not designed for this and may break if used in this capacity.



Accessories are available for your ODC JETPACK™. Ask for them where you bought your ODC JETPACK™, or visit the Creek Company Store at www.CreekCompany.com

The Creek Company Ltd. , PO Box 773892, Steamboat Springs, CO 80477

email: info@CreekCompany.com • Made in China

Specifications and other details subject to change without notice.

All Creek Company products are guaranteed against defects in material and workmanship for the life of the product to the original owner. This does not cover damage due to misuse or normal wear and tear.