



# ODC SUPERSPORT XR 1™

## OUTDOOR DISCOVERY CRAFT™

### ASSEMBLY INSTRUCTIONS

#### **THIS BOX CONTAINS:**

##### **STEEL FRAME**

- (1) Left Frame Member
- (1) Right Frame Member
- (1) Seat Support Frame Member with Underseat Lift and Lock Anchor System Attached
  - (1) Plastic Seat Back
  - (1) Plastic Seat Bottom
  - (4) Seat Screws
  - (2) Seat Assembly Pins
  - (2) Foot Bars
- (1) Cargo Deck with Motor Mount and Battery plate
  - (1) Stripping Apron
  - (8) Snap Pins
  - (1) Rod Holder

##### **OARS & OARLOCKS**

- (1) Pair 6-foot 2 piece Oars
- (1) Pair Clamp-on Oarlocks

##### **PONTOONS**

- (1) Left Pontoon
- (1) Right Pontoon
- (8) Cam Lock Straps

Each Pontoon consists of Nylon Cover with PVC bottom featuring integral Side Storage Pockets, and Main Bladder with Valve Insert and Valve Plate all preassembled.

##### **PUMP**

Complete with a set of Adaptors

# ODC SUPERSPORT XR 1™

## OUTDOOR DISCOVERY CRAFT™

### ASSEMBLY INSTRUCTIONS

#### I. PLASTIC SEAT ASSEMBLY

1. Assemble Seat Back to Seat Bottom using Seat Assembly Pins (see figure 1a).

#### II. ASSEMBLE FRAME

NOTE: Your Frame Assembles using (8) Snap Pins and (4) Seat Screws. Please follow instructions accordingly.

1. Assemble Seat to Seat Support Frame Member using (4) Seat Screws. (See Figure 1a)
2. Assemble Seat Support Frame Member to Left and Right Frame Members using (4) of the Snap Pins. (see figure 1)
3. Assemble Cargo Deck to Left and Right Frame Members using (2) Snap Pins (see figure 1).
4. Assemble Foot Bars to Left and Right Frame Members using (2) Snap Pins (see figures 1).
5. Assemble Rod Holder to Frame where Cargo Deck attaches to Right or Left Frame Members.

#### III. PONTOON INFLATION

**NOTE:** Use the large cone Adaptor provided with your Pump. See figure 3b for a detail of the Valve Assembly. **Before inflation, be sure to fully seat each Valve Assembly into the Pontoon, screwing tightly by hand. When fully seating Valve Assembly, be sure that the Valve Plate is in place around Valve Assembly and not restricting the Valve Assembly from a full seal. After inflating, be sure to fully seat the top cap on to each Valve Assembly, screwing tightly by hand. Both are required for an airtight seal.**

1. Inflate each Pontoon. The Valve is located inside the Storage Pocket of each Pontoon.(see figure 3).  
Inflate until firm (do not over inflate).
2. **Again, be sure top Valve Cap and Valve Assembly are fully seated.**

**PONTOON DEFLATION:** Unscrew entire Valve Assembly from Pontoon.

#### IV. ATTACH PONTOONS TO FRAME

**NOTE:** Always inflate the Pontoons first, before attaching to Frame.

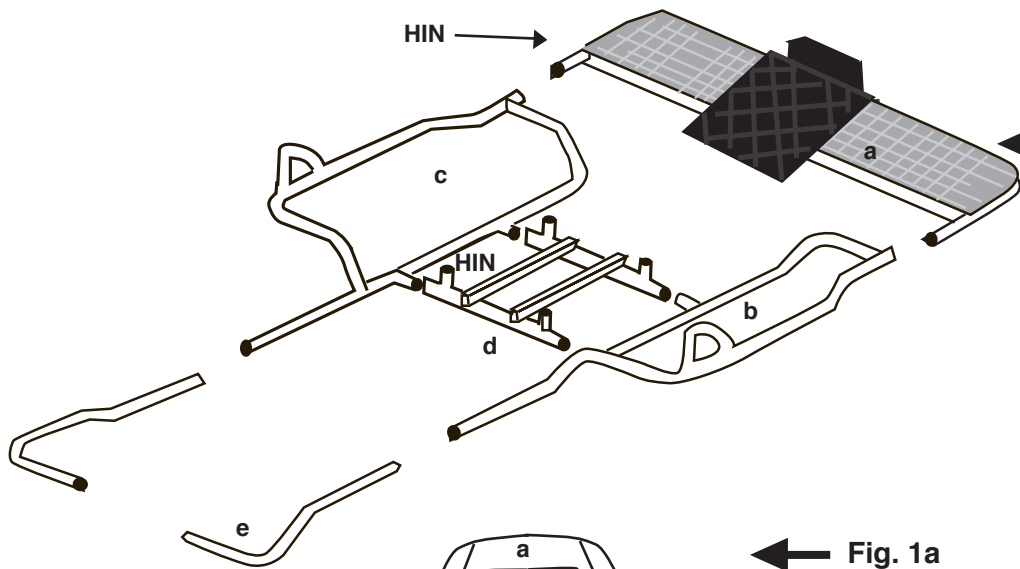
1. Position inflated Pontoons under the Left and Right Frame Members with ODC SUPERSPORT XR1™ logos oriented to the outside. The Frame Members fit around the Storage Pockets.
2. Attach Pontoons to Frame as illustrated in figures 3 and 3a. Note: Be sure the Straps are pulled tight through the Cam-lock Buckles. Frame should be positioned forward or aft on the Pontoons to achieve center of gravity for an even ride when fully loaded on the water.

#### V. OAR & OARLOCK ASSEMBLY

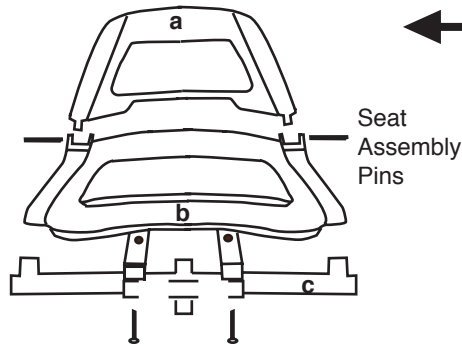
1. Loosen the wingnut on the Oarlock and slide the Oarlock onto the handle end of the Oar Shaft.
2. Attach blade end of Oar to end of Oar Handle .
3. Place Oarlock Shafts into Frame.
4. With the Oarlocks installed on the Frame, the oars should be equally adjusted left and right allowing at least two thumbs' distance between the Oars, to avoid pinching your thumbs when rowing. With the blades perpendicular to the water, tighten the wingnuts.

#### VI. ATTACH STRIPPING APRON TO FRAME

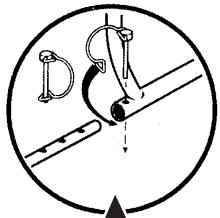
1. Snap front two Straps around the Frame underneath the Oarlocks, and snap the back two Straps to the Right and Left Frame Members just behind the Storage Pockets



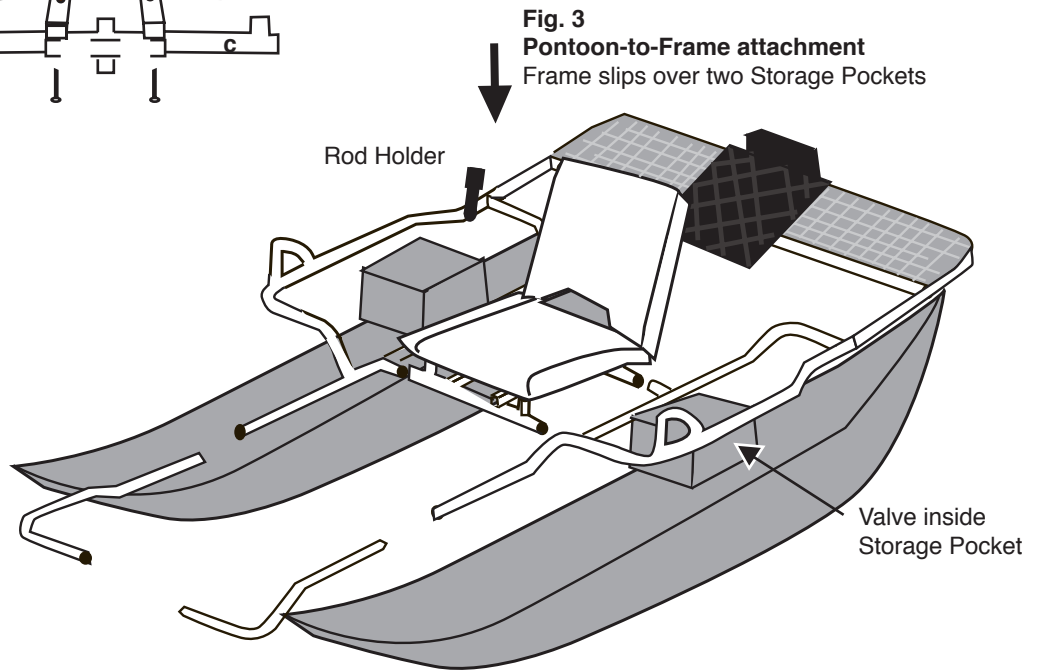
**Fig. 1**  
**Frame assembly**  
 a. Cargo Deck with Motor Mount  
 b. Left Frame Member  
 c. Right Frame Member  
 d. Seat Support Frame Member  
 e. Foot Bars



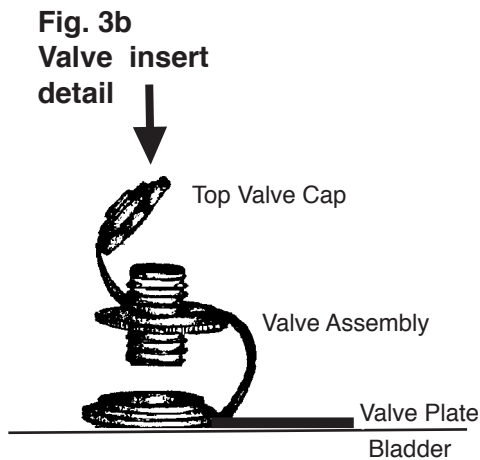
**Fig. 1a**  
**Seat Frame assembly**  
 a. Plastic Seat Back  
 b. Plastic Seat Bottom  
 c. Seat Support Member



**Fig. 2**  
**Detail of Snap Pin installation**  
 All Frame parts attach with Snap Pins.  
 Your Frame assembles using (8) Snap Pins. Please follow instructions accordingly.

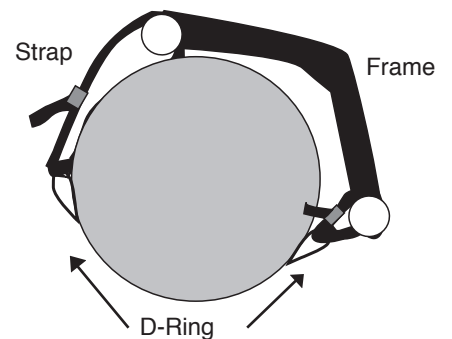


**Fig. 3**  
**Pontoon-to-Frame attachment**  
 Frame slips over two Storage Pockets



**Fig. 3b**  
**Valve insert detail**

**Fig. 3a**  
**Pontoon-to-frame attachment**  
 Detail of Camlock Strap



# ODC SUPERSPORT XR 1™

## OUTDOOR DISCOVERY CRAFT™

Your ODC Outdoor Discovery Craft™ is designed to give you many years of service. Please follow inflation instructions and warnings carefully.

**IF YOU EVER HAVE ANY QUESTIONS OR PROBLEMS WITH YOUR ODC SUPERSPORT XR 1™ PLEASE DO NOT RETURN IT TO THE DEALER YOU BOUGHT IT FROM. PLEASE CONTACT THE CREEK COMPANY DIRECTLY AT 970-879-5221. WE ARE OPEN M-F 9AM-5PM MOUNTAIN TIME. OR CONTACT US VIA E-MAIL AT INFO@CREEKCOMPANY.COM.**

**HIN is located on square tubing of seat support frame member and on right main frame member (See Figure 1)**

**Your Creek Company SUPERSPORT XR1™ is guaranteed against defects in material and workmanship for the life of the product to the original owner. This does not cover damage due to misuse or normal wear and tear.**

### Warning:

Please read and follow carefully.

1. Always wear a US Coast Guard approved personal flotation device when in your ODC SUPERSPORT XR 1™.
2. Never float alone.
3. Always check your ODC SUPERSPORT XR 1™ Air Bladders, outer skin and stitching for possible damage before you use your craft.
4. Never use your craft if you suspect the Air Bladders, outer skin or stitching has been damaged.
5. Never overinflate your ODC SUPERSPORT XR 1™.
6. Never use your ODC SUPERSPORT XR 1™ without the Pontoons fully inflated.
7. Your ODC SUPERSPORT XR1™ is not designed for use in salt water.

### CARE AND MAINTENANCE:

1. If your Pontoon Bladder is losing air, please check that Valve Assembly and Top Valve Cap are fully seated. Reseat valve assembly and repeat pontoon inflation instructions.
2. Do not store your ODC SUPERSPORT XR 1™ in direct sunlight.
3. If you are leaving your ODC SUPERSPORT XR 1™ out in the sun for any amount of time, be aware that the heat can increase the pressure inside the Pontoons to a dangerous level. Let some of the air out of the pontoons if the craft will be out of the water in the sun for any length of time, or if it is stored in a vehicle, etc.
4. A gain in altitude will increase the pressure in the Pontoons also. If you are taking your inflated ODC SUPERSPORT XR 1™ from a low elevation to a high elevation, be sure to let some of the air out of it.
5. For short term storage, we recommend you let some air out of your pontoons.
6. For long term storage, we recommend you make sure your ODC SUPERSPORT XR 1™ is completely dry, deflated and stored out of the sunlight in a cool dry area.. Do not store your wet ODC SUPERSPORT XR1™ in freezing temperatures as this may result in Frame and other component damage.
7. Repairing Bladder, use enclosed patch kit. Identify puncture. Fully deflate Bladder. Clean and dry area around puncture. Apply glue to puncture area and patch using applicator straw. Press patch over puncture area. Allow 24 hours to dry, before inflating.
8. Note: Metal parts may rust and are not covered under warranty.

**View instructional video at [www.creekcompany.com](http://www.creekcompany.com)**



Accessories are available for your ODC SUPERSPORT XR 1™. Ask for them where you bought your ODC SUPERSPORT XR 1™, or visit the Creek Company Store at [www.CreekCompany.com](http://www.CreekCompany.com)

**Creek Company, PO Box 773892, Steamboat Springs, CO 80477**  
email: [info@CreekCompany.com](mailto:info@CreekCompany.com) Made in China  
Specifications and other details subject to change without notice.